

101-S

EcoDesign

PANADERO



101-S DE

MAßE

MAßE H x B x T	627x1120x470 mm
GEWICHT BRUTTO/NETTO	176/170 kg
MAßE FEUERRAUMTÜR	885x300 mm
DURCHMESSER DES ABGASSTUTZEN	Ø 150-153 mm
	Vertikal

EIGENSCHAFTEN

ROST AUS GUSSEISEN	
NENNLEISTUNG	8,9 kW
WIRKUNGSGRAD	80,8 %
CO - EMISSIONEN	0,10 %
HITZESCHUTZANSTRICH	800°C
GLASKERAMIKSCHEIBE	750°C
HITZEBESTÄNDIG BIS	

EAN 8426964191004
REF. PANADERO 19100

PRODUKT PLUS

ECODESIGN



**EXTERNE
LUFTZUFUHR**



VERMICULIT
AUSKLEIDUNG



BEDRUCKTE
GLASKERAMIK



SCHEITLÄNGE 80 CM



270
m³

RAUMHEIZVERMÖGEN



SCHEIBENSPÜLUNG



DREIFACHVERBRENNUNG

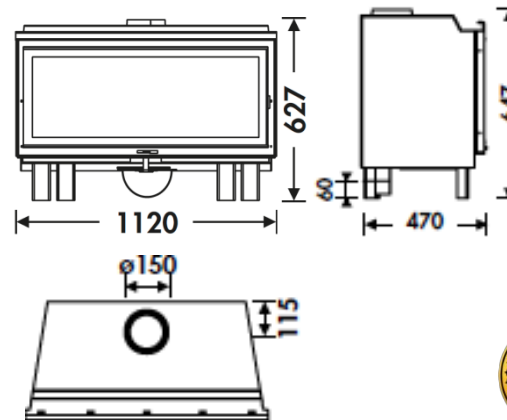

A+

