

OVAL 3 STONES EcoDesign

PANADERO



MAßE

MAßE H x B x T	1048x605x490mm
GEWICHT BRUTTO/NETTO	197/187 kg
MAßE FEUERRAUMTÜR	355x440 mm
DURCHMESSER DES ABGASSTUTZEN	Ø 150-153 mm Vertikal
EXTERNE LUFTZUFUHR	Ø 80 mm

EIGENSCHAFTEN

ROST AUS GUSSEISEN	
NENNLEISTUNG	8,7 KW
WIRKUNGSGRAD	80,7 %
CO - EMISSIONEN	0,10 %
HITZESCHUTZANSTRICH	800°C
GLASKERAMIKSCHEIBE	750°C
HITZEBESTÄNDIG BIS	

EAN 8426964183153
REF. PANADERO 18315

PRODUKT PLUS

ECODESIGN



EXTERNE
LUFTZUFUHR



VERMICULIT AUSKLEIDUNG



DOPPELBLECHGEHÄUS
E4 + 2 MM



HOLZFACH



SCHEITLÄNGE 50 CM



260
m³ RAUMHEIZVERMÖGEN



SCHEIBENSPÜLUNG



DREIFACHVERBRENNUNG



NATURSTEIN

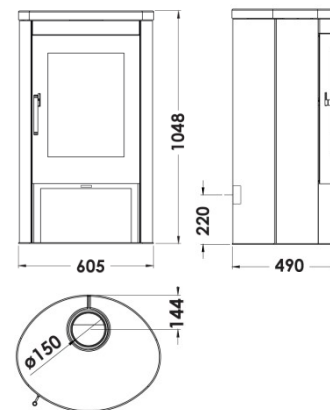

OVAL 3S DE



flamme
VERTE

Le label
du chauffage
au bois

7 ★